



- For your safety when you open the base flap, please install the safety lock.
- Please make sure the safety lock not installed while closing the base flap.
- While closing the base flap, make sure that any limb of your body is not between base and flap.
- Please be careful, base flaps can suddenly open by the high pressure at the lifts when there is no mattress on the base.
- Please don't let your children use it and go inside alone.



- Zu Ihrer sicherheit, legen Sie bitte die Sicherheitssperre ein während der Bettkasten geöffnet ist.
- Bitte achten Sie darauf, dass beim Schliessen des Bettkastens die Sicherheitssperre nicht eingesetzt ist.
- Bitte stellen Sie sicher, dass beim Schliessen der Bettkastens sich keine Körperteile zwischen der Basis und der Klappe befinden.
- Bitte beachten Sie, dass der hohe Druck der Federungen die plötzliche Öffnung der Klappe verursachen kann, wenn sich keine Matratze auf dem Bettkasten befindet.
- Bitte lassen Sie nicht zu, dass Ihre Kinder den Bettkasten öffnen oder in ihn hineintreten.







- Pour votre sécurité, lors de l'ouverture du volet de la base, veuillez installer le verrou de sécurité.
- Assurez-vous que le verrou de sécurité n'est pas installé lors de la fermeture du volet de la base.
- Lors de la fermeture du volet de la base, assurez-vous qu'aucune partie de votre corps ne se trouve entre la base et le volet.
- Faites attention, les volets de la base peuvent s'ouvrir soudainement en raison de la haute pression des vérins lorsqu'il n'y a pas de matelas sur la base.
- Ne laissez pas votre enfant l'utiliser sans surveillance ni le laisser entrer à l'intérieur.

ASSEMBLY INSTRUCTION









DOUBLE BED BASE SETUP INSTRUCTION

CIRCLE (U) LEG

BOM ID	DESCRIPTION	QUANTITY
A 	STANDART LEGS	6x
B 	HIDDEN LEGS	6x
C 	SCREW	5x
D 	THUMBSCREW	6x
E 	SCREW *	6x or 4x or 2x
F 	HANDLE **	2x

CORNER (L) LEG

BOM ID	DESCRIPTION	QUANTITY
A 	"L" LEGS	6x
B 	HIDDEN LEGS	6x
C 	SCREW	5x
D 	THUMBSCREW	6x
E 	SCREW *	6x or 4x or 2x
F 	HANDLE **	2x
G 	SCREW	24x





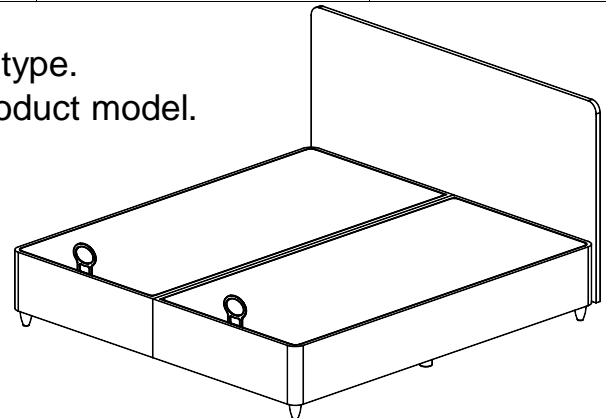

*The quantity of screws may be depending on the handle type.

** The Handle type may be different depending on the product model.









AUFBAUANLEITUNG FÜR DOPPELBETTBASIS

RUNDES (U) BEIN

BOM ID	BESCHREIBUNG	MENGE
A 	STANDARD-BEINE	6x
B 	VERSTECKTE BEINE	6x
C 	SCHRAUBE	5x
D 	FLÜGELSCHRAUBE	6x
E 	SCHRAUBE	6x or 4x or 2x
F 	GRIFF **	2x

ECKIGES (L) BEIN

BOM ID	BESCHREIBUNG	MENGE
A 	L-FÖRMIGE BEINE	6x
B 	VERSTECKTE BEINE	6x
C 	SCHRAUBE	5x
D 	FLÜGELSCHRAUBE	6x
E 	SCHRAUBE	6x or 4x or 2x
F 	GRIFF **	2x
G 	SCHRAUBE	24x





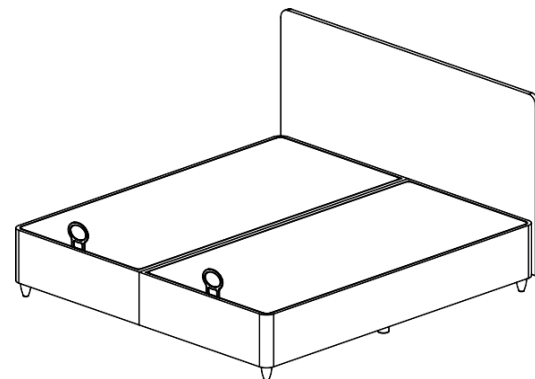

*Die Menge der Schrauben kann vom Griff-Typ abhängen.

**Der Griff-Typ kann je nach Produkt unterschiedlich sein.









INSTRUCTIONS DE MONTAGE DE LA BASE DE LIT DOUBLE

PIED CIRCULAIRE (U)

BOM ID	DESCRIPTION	QUANTITÉ
A 	PIEDS STANDARDS	6x
B 	PIEDS CACHÉS	6x
C 	VIS	5x
D 	VIS À MAIN	6x
E 	VIS *	6x ou 4x ou 2x
F 	POIGNÉE **	2x

PIED D'ANGLE (L)

BOM ID	DESCRIPTION	QUANTITÉ
A 	PIEDS EN "L"	6x
B 	PIEDS CACHÉS	6x
C 	SC VIS REW	5x
D 	VIS À MAIN	6x
E 	VIS *	6x ou 4x ou 2x
F 	POIGNÉE **	2x
G 	VIS	24x

*La quantité de vis peut dépendre du type de poignée.

**Le type de poignée peut varier en fonction du produit.

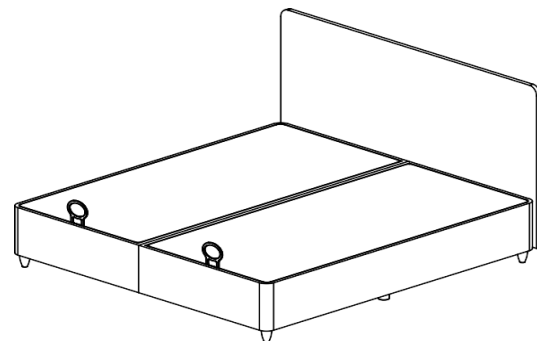

1.STEP (CIRCLE "U" LEG)

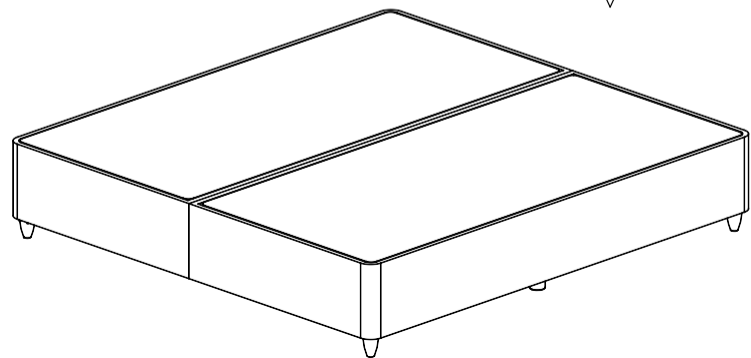
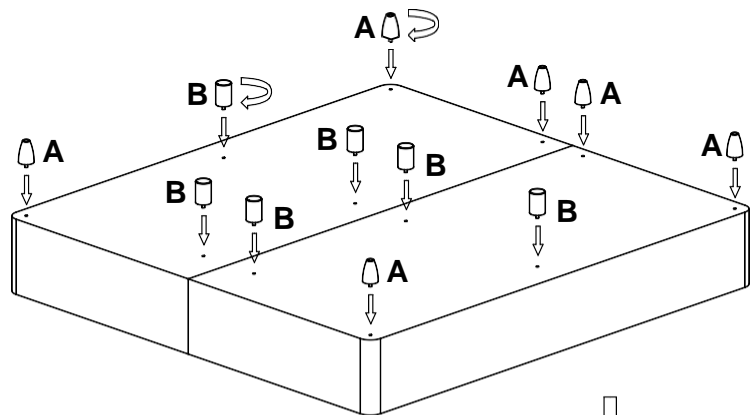

1.STEP (CORNER "L" LEG)

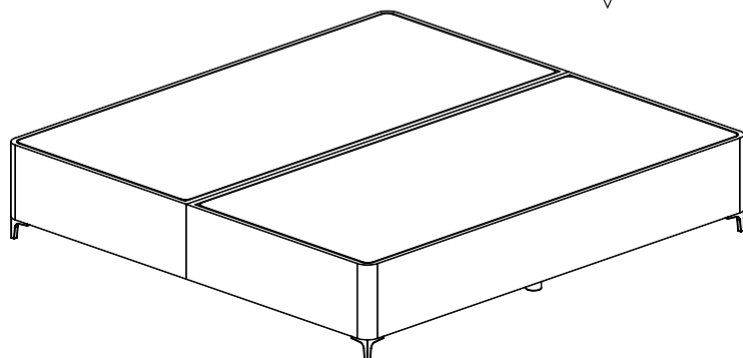
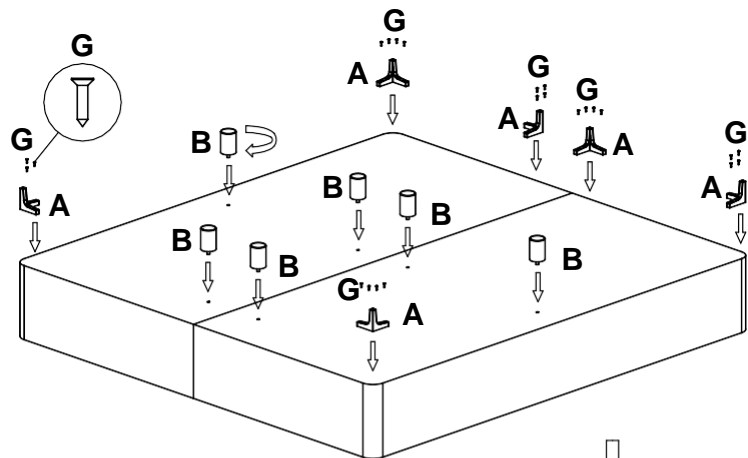

2.STEP

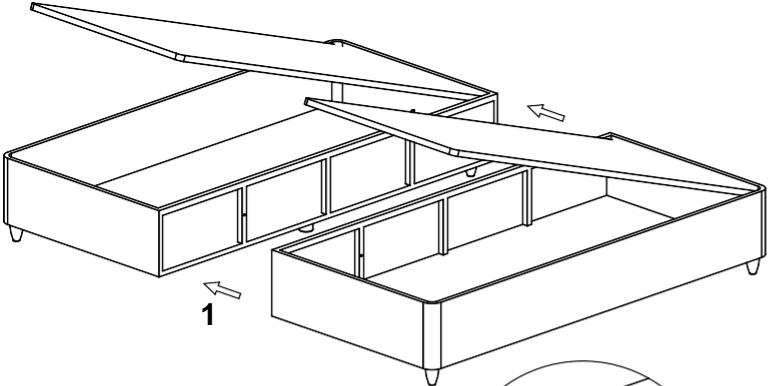

2

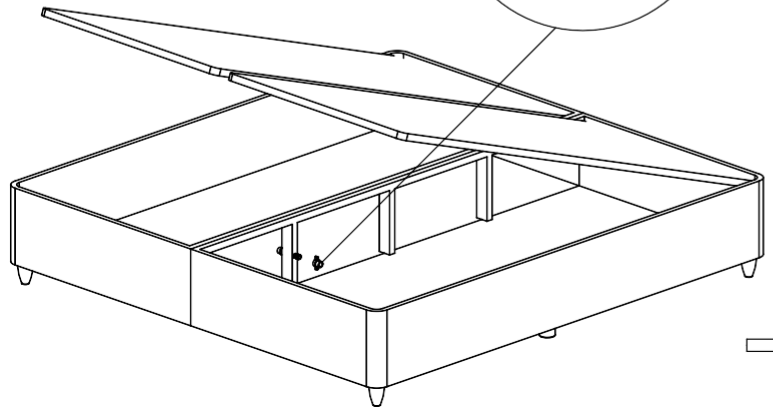
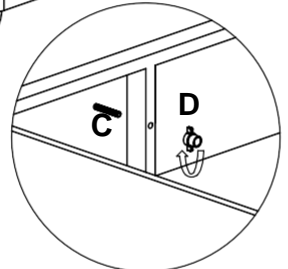

3

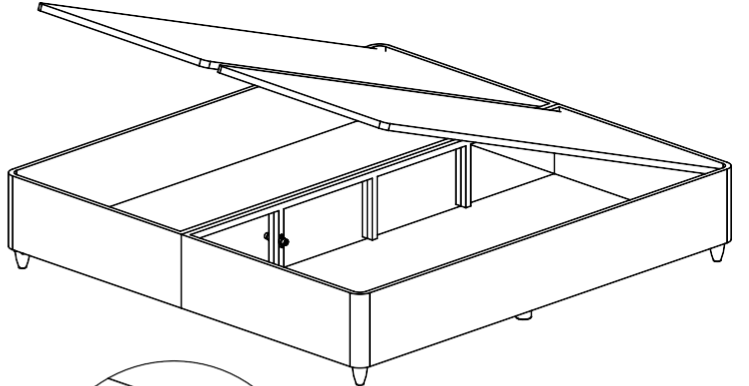

4

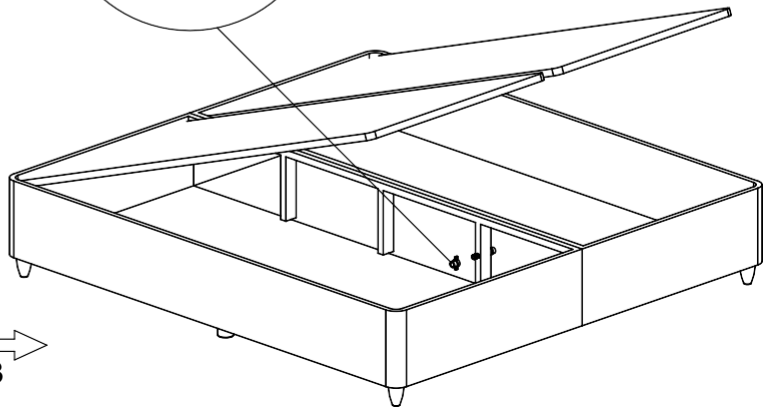
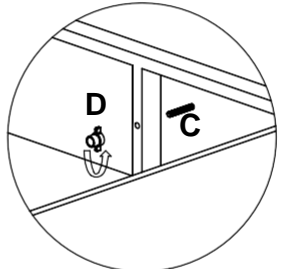

3.STEP

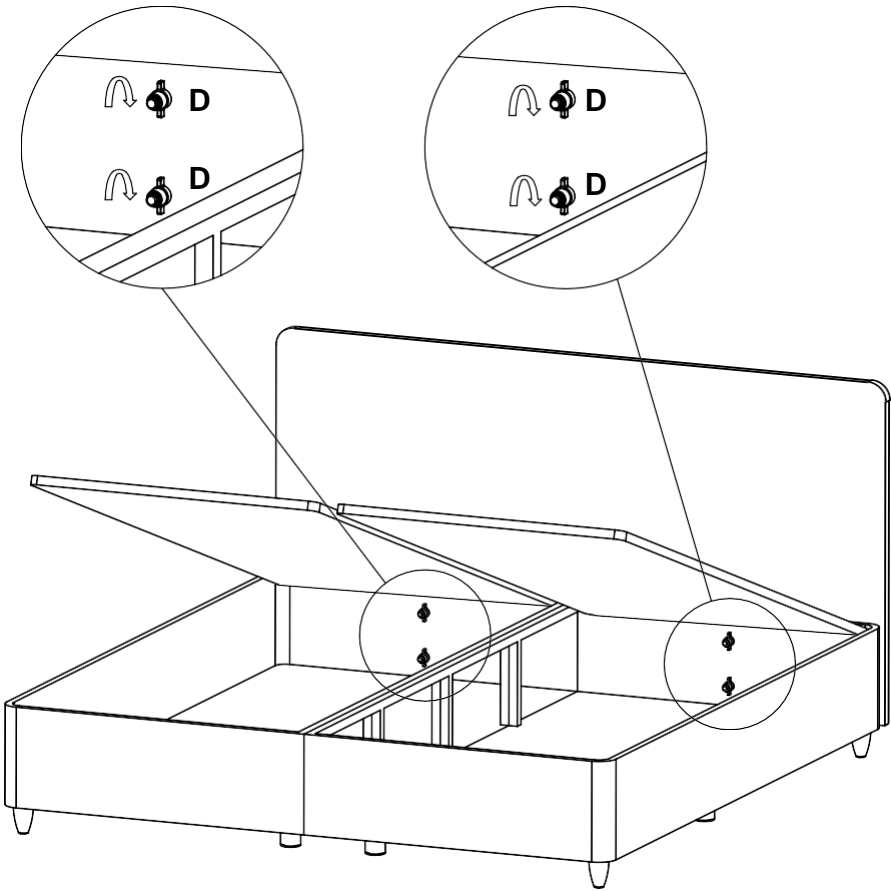
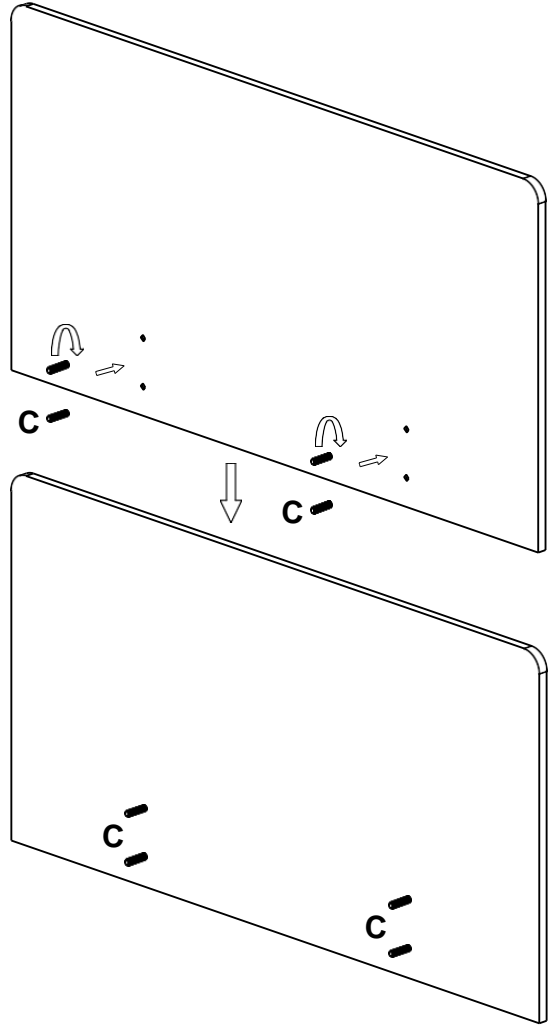

4.STEP

